

Precision Force & Frequency for a Range of Applications



Application

These compact robust range of Linear vibrators are suitable for use in a wide number of applications, to assist in the flow and control of many materials. The following being some of the more common:

| | |
|-----------------|---|
| Feeders: | Natural Frequency Feeders Particularly good for feeding light materials where large amplitudes are required. |
| Tables: | For packing industry, foundries for core making, loads up to 2200 Lbs. |
| Screens: | Very effective on small screens for materials of low specific gravity, granular materials and powder. |
| Hoppers: | Certain applications where larger materials bridge. Not suitable for sticky or rat-holing materials. |

Description

VTL Series Linear Piston Vibrators provide quiet linear vibrating force using an air cushioned piston. Frequency and amplitude can be controlled independently – Frequency is controlled by varying air pressure, and amplitude is varied by changing the weight of the vibrating mass.

The VTL Series Vibrators can be mounted by the piston, or by the housing; therefore, either the piston or the housing can be used as the vibrating mass. Additional weights can also be added to the free end of the vibrator, further increasing the range of available amplitudes. Using additional masses the vibrator is able to work at low frequencies, down to 15 Hz and to generate large amplitudes.

VTL vibrators combine the advantages of low frequency rotary vibrators (large amplitudes) with those of magnetic vibrators (adjustable amplitudes). Additionally, they have the advantage of being able to select the most suitable frequency to obtain optimum results.

Contact a member of the Houston Vibrator Sales Team for selection and sizing assistance for YOUR Application.

Accessories

Exhaust mufflers and air inlet fittings are supplied with the VTL Series Vibrators.

Please contact a member of the Houston Vibrator Sales Team for recommendations and pricing on air preparation and control components.

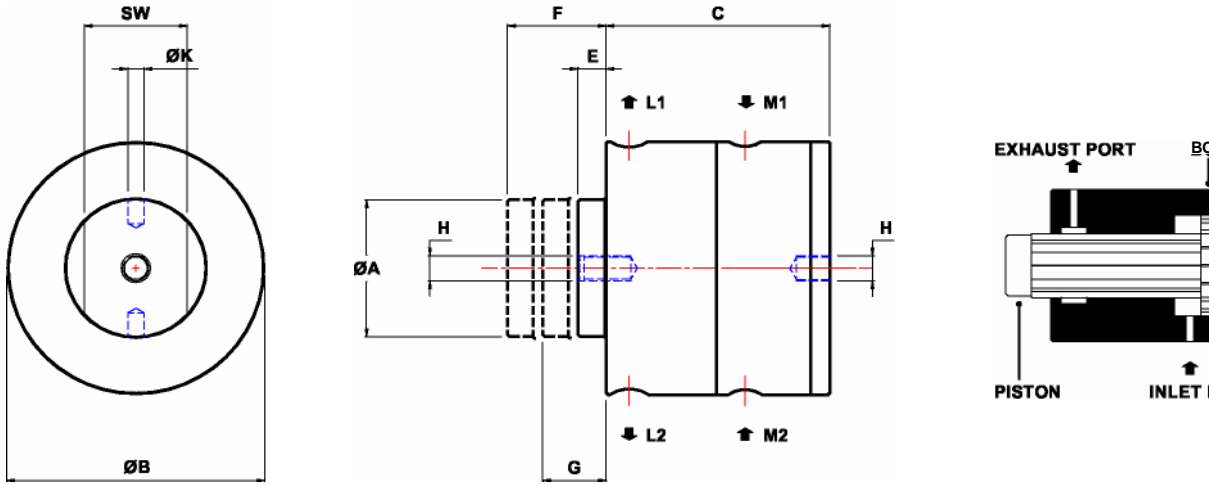

Dimensions

| Model | A | B | C | E | F | G | H | K | L1 | L2 | M1 | M2 | SW | Weight Lbs. |
|----------|------|------|------|------|------|------|-----|------|------|------|------|------|------|-------------|
| VTL 155 | 0.63 | 1.97 | 4.49 | 0.35 | 1.70 | 0.59 | M10 | - | 1/8" | - | 1/8" | - | 0.51 | 1.15 |
| VTL 165 | 0.65 | 1.93 | 4.37 | 0.20 | 1.57 | 0.73 | M10 | - | 1/8" | - | 1/8" | - | 0.55 | 3.29 |
| VTL 255 | 1.00 | 2.52 | 5.51 | 0.35 | 2.13 | 1.08 | M16 | - | 1/4" | - | 1/4" | - | 0.87 | 7.03 |
| VTL 405 | 1.59 | 3.31 | 5.51 | 0.47 | 2.24 | 0.94 | M16 | - | 1/4" | - | 1/4" | - | 1.23 | 12.06 |
| VTL 555 | 2.19 | 4.53 | 4.92 | 0.67 | 2.15 | 0.78 | M20 | - | 3/8" | - | 3/8" | - | 1.81 | 17.24 |
| VTL 855 | 3.37 | 6.30 | 4.80 | 0.79 | 2.15 | 0.66 | M20 | 0.50 | 3/8" | 3/8" | 3/8" | - | - | 37.29 |
| VTL 1105 | 4.35 | 7.87 | 4.80 | 0.87 | 2.15 | 0.56 | M20 | 0.50 | 1/2" | 1/2" | 1/2" | 3/8" | - | 56.96 |

Performance Data

| MODEL | Frequency VPM | Force (Lbs) | | Air Consumption CFM |
|----------|---------------|-------------|---------|---------------------|
| | max. | min. | max. | max. |
| VTL 155 | 2600 | 8.77 | 24.73 | 3.18 |
| VTL165 | 2600 | 8.77 | 41.59 | 2.65 |
| VTL 255 | 1900 | 20.23 | 161.86 | 7.06 |
| VTL 405 | 1900 | 49.46 | 325.97 | 14.40 |
| VTL 555 | 2400 | 114.65 | 593.50 | 26.65 |
| VTL 855 | 2500 | 189.96 | 1740.02 | 32.62 |
| VTL 1105 | 2900 | 394.40 | 1344.36 | 33.89 |